

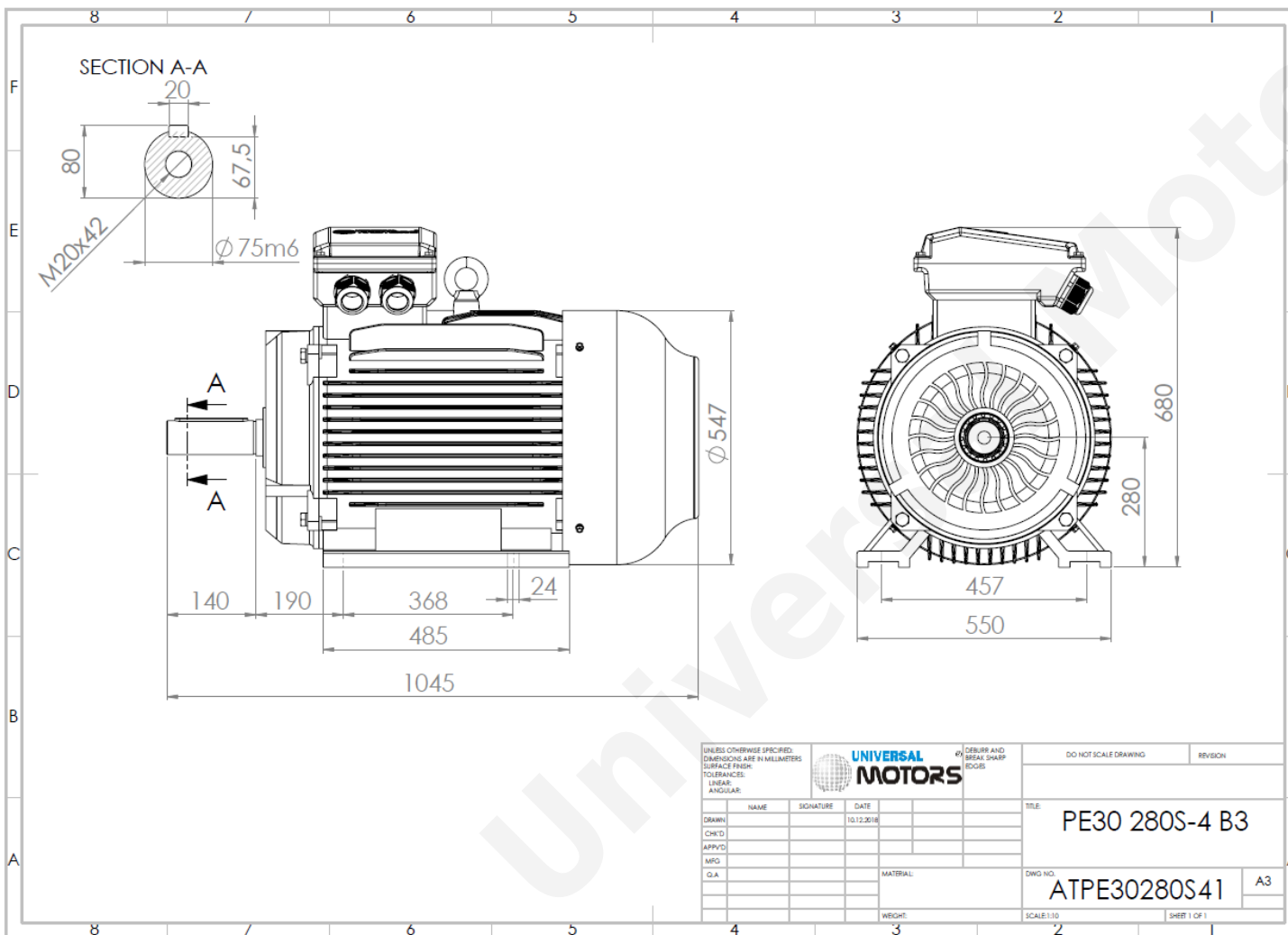

TECHNICAL DATA

Three Phase Electric Motors - Cast Iron Frame
 PE30 280 S 4 IE3
 75 kW / 100 Cv
 1485 RPM



Motor type:	PE30 280 S 4 IE3
Output:	75 kW / 100 Cv
Speed (min ⁻¹):	1485 RPM
Frequency:	50 Hz
Voltage:	400 V
Current:	129 A
Power factor (Cos ϕ):	0.88
Poles:	4
Insulation class:	F
Temperature rise Class:	B
Efficiency 50%:	94.2 %
Efficiency 75%:	95.1 %
Efficiency 100%:	95.0 %
Torque:	482 N.m
Tstarting/Tnominal:	2.0
Istarting/Inominal:	6.9
Tmaximum/Tnominal:	2.3
Noise:	69 Db(A)
Weight:	600 Kg
Bearing DE:	6317 C3
Bearing NDE:	6317 C3

Regime - S1

Altitude - 1000m

Environment Temperature - 40°C

CONTACTS:

UNIVERSAL MOTORS Tel: +351 252 299 080
 Rua de São Brás,745 Fax: +351 252 299 089
 4480-782 VILA DO CONDE Mail: geral@universalmotors.pt

* References applied only in the UK